

# CX225SR Crawler excavator

## Table of contents

	REFERENCE N°
SERVICE MANUAL.....	9-40691EN
SUPPLEMENT SERVICE MANUAL .....	9-40691R1 (CX225SR, DC22U0208...)
ENGINE SERVICE MANUAL (BB - 6BG1T) .....	*
LARGE FORMAT HYDRAULIC AND ELECTRICAL SCHEMATICS (CX225SR...DC22U0207) .....	9-43710
LARGE FORMAT HYDRAULIC SCHEMATIC (CX225SR, DC22U0208...) .....	87576796A
LARGE FORMAT HYDRAULIC SCHEMATIC (DOZER BLADE) (CX225SR, DC22U0208...) .....	87608327A
LARGE FORMAT ELECTRICAL SCHEMATIC (CX225SR, DC22U0208...).....	87576801A

\* *Consult the Engine Service Manual*

### Configurations contained in this Service Manual:

CX225SR NA	(North Model América)
CX225SR WE	(Model Europe)

NOTE: CNH Company reserves the right to make changes in the specification and design of the machine without prior notice and without incurring any obligation to modify units previously sold.

The description of the models shown in this manual has been made in accordance with the technical specifications known as of the date of design of this document.





## REPAIR MANUAL

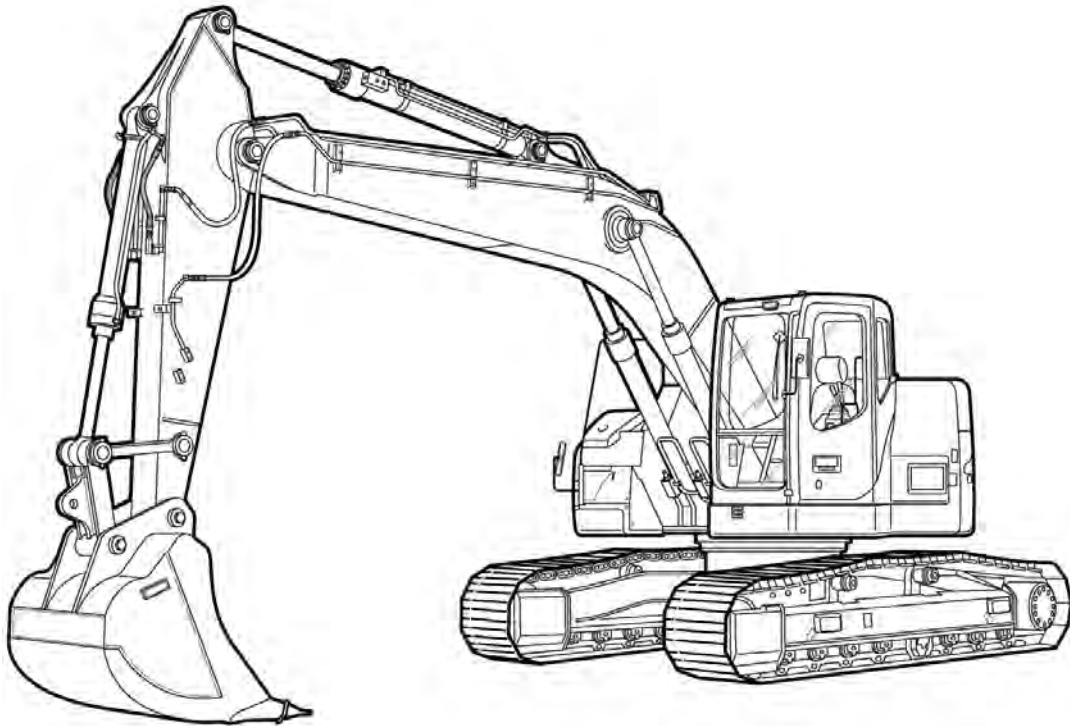

**CX225SR**

# Contents

---

INTRODUCTION  
DISTRIBUTION SYSTEMS  
POWER PRODUCTION  
TRAVELLING  
BODY AND STRUCTURE  
FRAME POSITIONING  
WORKING ARM  
TOOLS AND COUPLERS

A  
B  
D  
E  
F  
H  
J

**Thanks very much for your reading,  
Want to get more information,  
Please click here, Then get the complete  
manual**

**JustClickHere** 

**NOTE:**

**If there is no response to click on the link above,  
please download the PDF document first, and then  
click on it.**

**Have any questions please write to me:  
[admin@servicemanualperfect.com](mailto:admin@servicemanualperfect.com)**



# INTRODUCTION

# Contents

---

## INTRODUCTION

Foreword ( - A.10.A.40) CX225SR	3
Safety rules ( - A.50.A.10) CX225SR	4
Basic instructions ( - A.90.A.05) CX225SR	6
Torque ( - A.90.A.10) CX225SR	7
Torque ( - A.90.A.10) CX225SR	8
Dimension ( - A.92.A.30) CX225SR	11
Weight ( - A.92.A.40) CX225SR	12
Consumables ( - A.92.A.55) CX225SR	13
Hydraulic contamination ( - A.92.A.60) CX225SR	16
Product identification ( - A.80.A.10) CX225SR WE	18
Product identification ( - A.80.A.10) CX225SR NA	19

## Foreword ( - A.10.A.40)

CX225SR

### INTRODUCTION TO THE REPAIR MANUAL

This manual has been designed so that in the near future it can be made available on CD and in a database via a computer network.

This will allow fast and targeted search and navigation between the various information modules.

### Information search

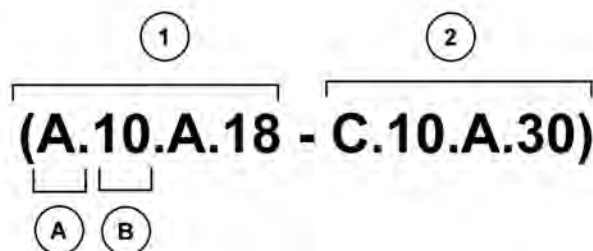

CRIL03J033E01 1

This manual is organised according to types of function and information.

- The function and information types are codified and appear in parentheses after the title and separated by a dash:  
**(1)** Function  
**(2)** Information type.
- Only the first letter **(A)** and the first number **(B)** of the function need to be used for the information search.  
 The first letter **(A)** corresponds to the sections of the repair manual.  
 The first number **(B)** corresponds to the chapters of the repair manual.  
 The first part of the **(A.B)** code is reflected in the page numbering.  
 THE REST OF THE CODING IS NOT LISTED IN ALPHA-NUMERIC ORDER IN THIS MANUAL.
- You will find a table of contents at the beginning and end of each section and chapter.  
 You will find an alphabetical index at the end of each chapter.
- Therefore it is the first part of the **(A.B)** coding, then the tables of contents and index (page numbers) which will allow you to quickly find the information you are looking for.



## Safety rules ( - A.50.A.10)

CX225SR

**CAUTION**

**M171C - THIS SAFETY ALERT SYMBOL INDICATES IMPORTANT SAFETY MESSAGES IN THIS MANUAL. WHEN YOU SEE THIS SYMBOL, CAREFULLY READ THE MESSAGE THAT FOLLOWS AND BE ALERT TO THE POSSIBILITY OF DEATH OR SERIOUS INJURY.**

**ATTENTION:** To avoid injury, always observe the Safety Notices, CAUTION and ATTENTION, contained in this section and throughout the manual.

Place a "Do not start the machine" warning notice on the starter switch key before all maintenance or repair operations.

**CAUTION**

**M489 - Read the operators manual to familiarize yourself with the correct control functions.**

**CAUTION**

**M490 - Operate the machine and equipment controls from the seat position only. Any other method could result in serious injury.**

**CAUTION**

**M265A - A frequent cause of personal injury or death is persons falling off and being run over. Do not permit anyone to ride on the machine.**

**CAUTION**

**SB055 - Before starting engine, study operators manual safety messages. Read all safety signs on machine. Clear the area of other persons. Learn and practice safe use of controls before operation. It is your responsibility to understand and follow manufacturers instructions on machine operation, service, and to observe pertinent laws and regulation. Operators and service manuals can be obtained from your dealer.**

**ATTENTION:** You risk injury if you wear loose clothing or if you do not use safety equipment for your work. Always wear clothes which are unlikely to become caught in the machinery. Other safety equipment may be required, in particular: hard hat, safety boots, ear protectors, safety goggles or mask, thick gloves and reflective clothing.

**CAUTION**

**M124A - Rotating machine parts, stay clear, keep shields installed to help protect from clothing entanglement and injury. Wear close-fitted clothing.**

**CAUTION**

**SB071 - Rotating fan and belts: Contact will cause injury. Keep clear.**

**ATTENTION:** Follow the procedures exactly when carrying out checks or inspections on the vehicle's hydraulic systems. DO NOT CHANGE the procedures.

**ATTENTION:** Before running the hydraulic cylinders in this vehicle through the cycles necessary for checking their functioning or for draining a circuit, warn people nearby to move away.

**CAUTION**

**SM121A - Always wear heat protective gloves to prevent burning your hands when handling heated parts.**

**CAUTION**

**M132B - Lower or block elevated implements and other attachments before servicing or when leaving the equipment.**

**CAUTION**

**R149C - Hydraulic oil or diesel fuel leaking under pressure can penetrate the skin and cause infection or other injury. To Prevent Personal Injury: Relieve all pressure, before disconnecting fluid lines or performing work on the hydraulic system. Before applying pressure, make sure all connections are tight and components are in good condition. Never use your hand to check for suspected leaks under pressure. Use a piece of cardboard or wood for this purpose. If injured by leaking fluid, see your doctor immediately.**

**ATTENTION:** *To remove a hardened pin, such as a pivot pin, or a hardened shaft, use a soft-headed hammer (brass or bronze) or a brass or bronze peg and a steel-headed hammer.*

**CAUTION**

**M428 - Always wear safety glasses when using a drill, hammer, saw, or other tools that may cause chips to fly.**

**ATTENTION:** *Use suitable servicing jacks or a chain hoist for raising the wheels or tracks. Always chock the vehicle in place with suitable safety supports.*

**ATTENTION:** *When carrying out maintenance or repair operations on the vehicle, keep the workshop floor, the driving position and the steps free from oil, water, grease, tools, etc... Use an oil absorbent material and/or workshop cloths as necessary. Always use sound methods.*

**ATTENTION:** *Some parts of this vehicle are very heavy. Use lifting devices or additional assistance recommended in the Operator's Manual.*

**CAUTION**

**M532 - Do not operate the engine in a closed building. Proper ventilation is required under all circumstances.**

**CAUTION**

**M503 - When the battery electrolyte is frozen, the battery can explode if (1), you try to charge the battery, or (2), you try to jump start and run the engine. To prevent the battery electrolyte from freezing, try to keep the battery at full charge. If you do not follow these instructions, you or others in the area can be injured.**

**CAUTION**

**M244A - BATTERIES CONTAIN ACID AND EXPLOSIVE GAS. EXPLOSION CAN RESULT FROM SPARKS, FLAMES, OR WRONG CABLE CONNECTIONS. TO CONNECT JUMPER CABLES OR CHARGER, SEE MANUAL(S) FOR THE CORRECT PROCEDURE. FAILURE TO FOLLOW THE ABOVE INSTRUCTIONS CAN CAUSE SERIOUS PERSONAL INJURY OR DEATH.**

## Basic instructions ( - A.90.A.05)

CX225SR

### GENERAL

#### Cleaning

Clean all metal parts except the bearings with white spirit or steam. Do not use caustic soda for steam cleaning. After each cleaning, dry and oil all parts. Clean the oil ducts with compressed air. Clean the bearings with paraffin, then dry them completely and lubricate them.

#### Inspection

Check all the parts when they are disassembled. Replace all parts that show signs of wear or damage. Superficial scratches and grooves can be removed with an oil stone or with a cloth dipped in red oxide. A complete visual inspection is necessary to detect wear and pitting, and replacing parts as soon as it becomes necessary will help to avoid premature breakdowns.

#### Bearings

Check that the bearings turn freely. Replace them if their adjustment is too free or if their functioning is irregular. Wash the bearings with a good solvent or paraffin and allow them to air dry.  
DO NOT DRY THE BEARINGS WITH COMPRESSED AIR.

#### Needle bearings

Before pushing needle bearings into a cylinder bore, always remove all metallic projections from the bore and its edges. Before pushing in bearings with a press, coat the inside and edges of the bearings with Vaseline.

#### Gears

Check all the gears and ensure that they do not show any signs of wear or damage. Replace the worn out or damaged gears.

#### Gaskets, O-rings and flat seals

Always install new gaskets, O-rings, and flat seals. Coat the gaskets and O-rings with Vaseline.

#### Shaft

Check all shafts showing wear or damage. Ensure that the surface of a shaft carrying a bearing or gasket is not damaged.

#### Spare parts

Always use CASE spare parts. To order these, refer to the Spare Parts Catalogue and indicate the correct reference number of the CASE spare parts.  
Breakdowns caused by the use of parts other than CASE spare parts are not covered by the warranty.

#### Lubrication

Use only the oils and lubricants specified in the Operator's Manual or the Service Manual.  
Breakdowns caused by the use of oils and lubricants not specifically listed are not covered by the warranty.

# Torque ( - A.90.A.10)

CX225SR

## STANDARD TIGHTENING TORQUE

### Order of tightening nuts and cap screws.

Tighten alternately so that torque remains uniform. Cap screws which are fitted with Loctite (look for traces of a white residue on the thread after removal), must be cleaned with a thin oil or a suitable solvent, then dried. Add two or three drops of Loctite to the cap screw thread, then fit the screw.

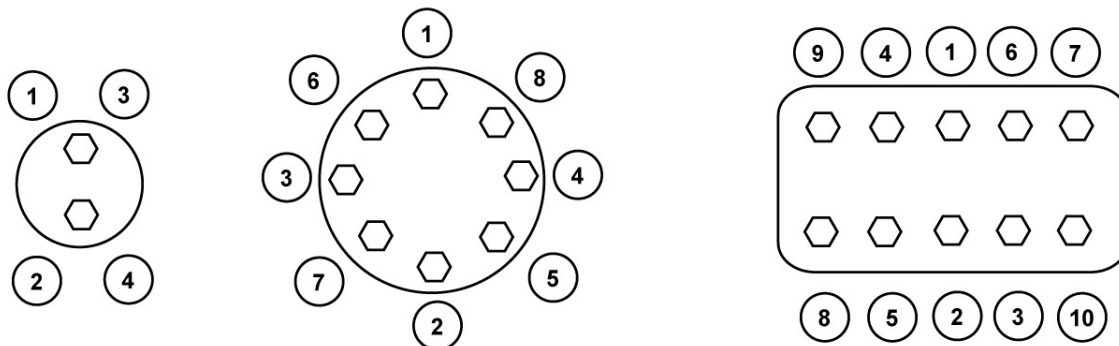

CRIL03H012E01

CRIL03H012E01 1

The numbers in the diagrams represent the order of tightening.

### Tightening torque

Where there are no special instructions, tighten cap nuts screws to the torques given in the table below.

#### Standard torque setting table.

Designation of cap screws (dimensions)		M6	M8	M10	M12	M14	M16	M18	M20
Cap screw	Spanner in mm	10	13	17	19	22	24	27	30
	Torque setting in Nm	6.9	19.6	39.2	58.8	98.1	157.2	196	274
Socket head screw	Wrench in mm	5	6	8	10	12	14	14	17
	Torque setting in Nm	8.8	21.6	42.1	78.4	117.6	176.4	245	343

## Torque ( - A.90.A.10)

CX225SR

### SPECIAL TORQUE SETTINGS

No.	Component	Screw diameter	Wrench in mm	Tightening torque
(1)*	Travel motor and reduction gear assembly	M16	24	267 - 312 Nm
(2)*	Sprocket	M16	24	267 - 312 Nm
(3)*	Idler wheel	M16	24	267 - 312 Nm
(4)*	Upper roller	M20	30	521 - 608 Nm
(5)*	Lower roller	M18	27	371 - 432 Nm
(6)	Chain guide	M18	27	380 - 443 Nm
(7)	Track pad	M20	30	300 Nm+120 °
(8)	Counterweight	M36	55	2750 - 2940 Nm
(9)	Turntable (chassis)	M20	30	468 - 545 Nm
(10)	Turntable (upperstructure)	M20	30	468 - 545 Nm
(11)*	Swing motor and reduction gear assembly	M20	30	521 - 608 Nm
(12)*	Engine	M16	24	265 - 313 Nm
(13)*	Engine mounts	M10	17	64 - 74 Nm
(14)	Radiator	M16	24	147 - 176 Nm
(15)*	Hydraulic pump	M10	17	64 - 74 Nm
		M20	30	367 - 496 Nm
(16)*	Hydraulic reservoir	M20	30	412 - 471 Nm
(17)*	Fuel tank	M20	30	412 - 471 Nm
(18)*	Control valve	M16	24	267 - 312 Nm
(19)*	Hydraulic swivel	M12	19	109 - 127 Nm
(20)	Cab	M16	24	78 - 80 Nm
(21)	Batteries	M10	17	20 - 29 Nm

Use Loctite 262 or an equivalent on mounting screws marked with an asterisk (\*).

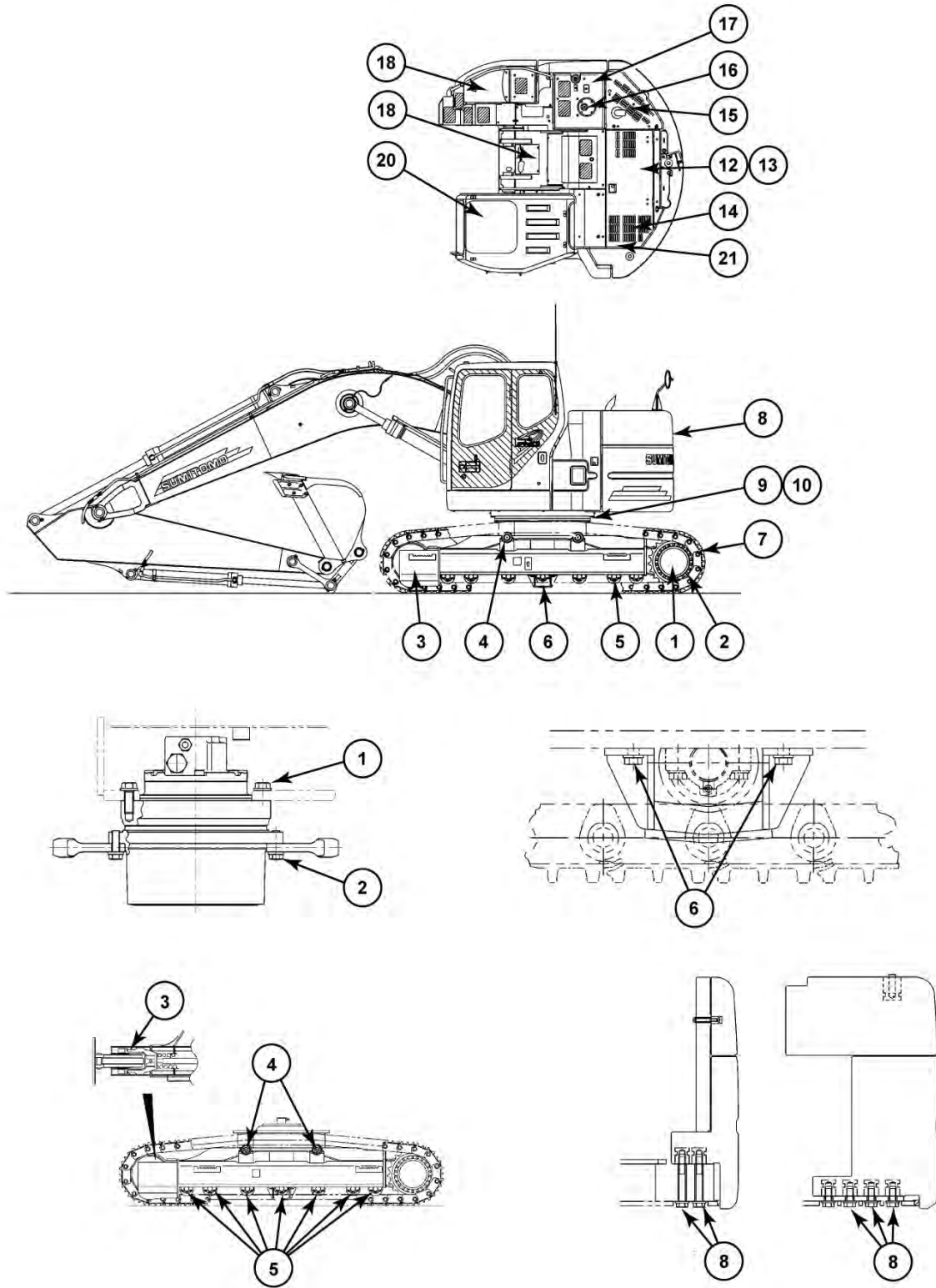

CRIL04B072H01 1

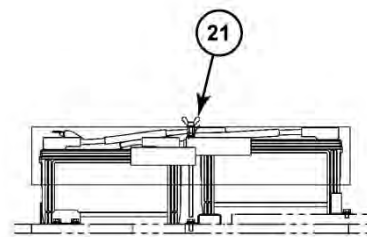
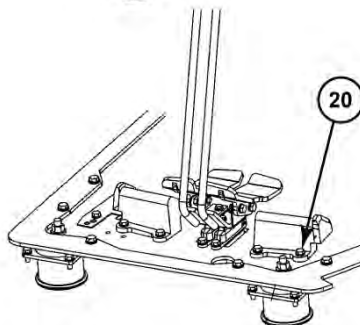
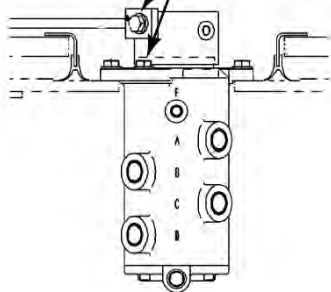
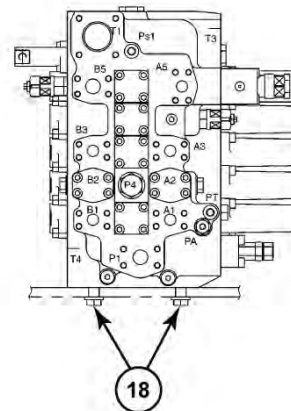
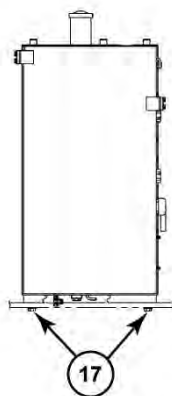
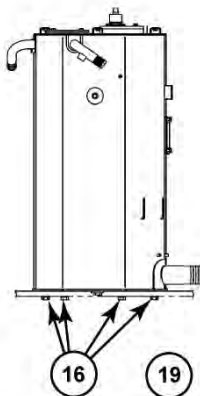
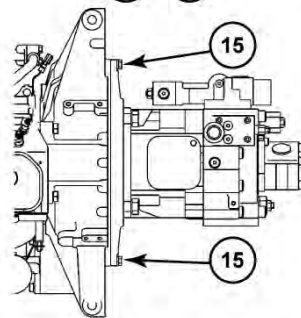
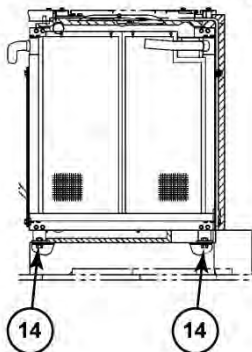
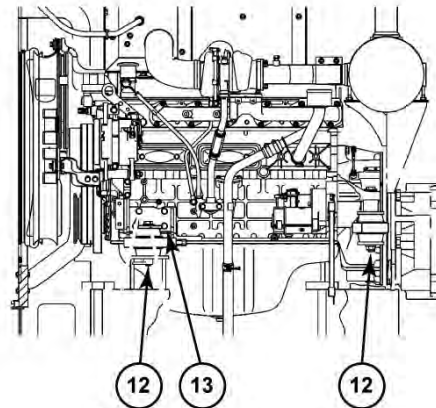
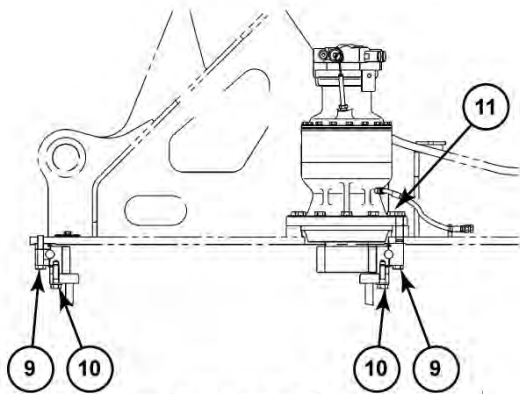

CRIL04B073H01 2

# Dimension ( - A.92.A.30)

CX225SR

Machine fitted with monobloc boom 5.70 m

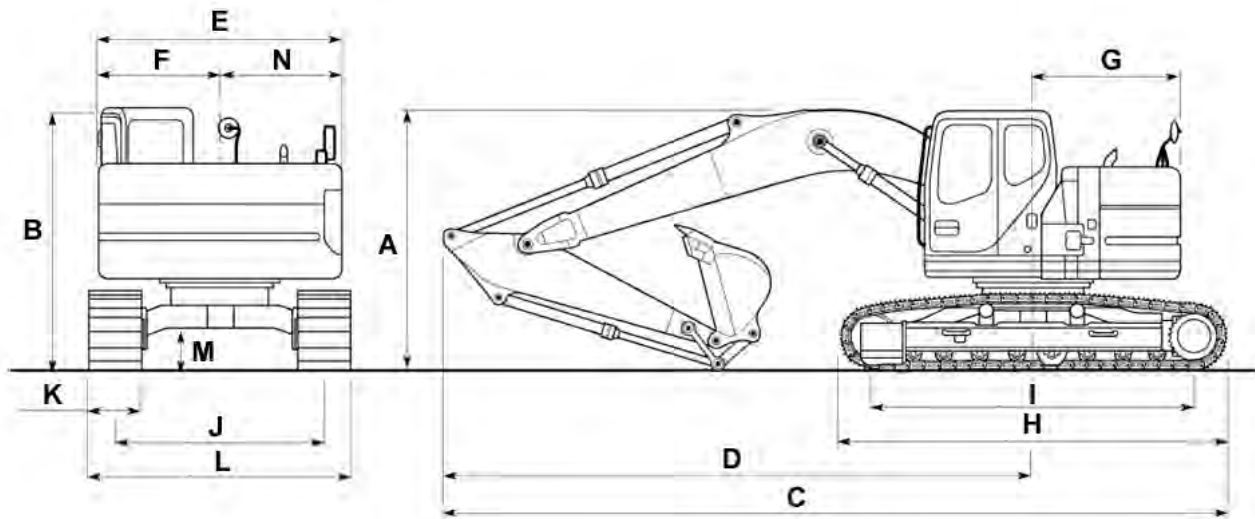

CRPH04B001F00 1

Dippers	1.90 m	2.40 m	3.00 m
(A)	3.08 m	3.14 m	2.90 m
(B)	2.97 m		
(C)	8.97 m	8.93 m	8.85 m
(D)	6.74 m	6.70 m	6.62 m
(E)	2.80 m		
(F)	1.40 m		
(G)	1.68 m		
(H)	4.46 m		
(I)	3.66 m		
(J)	2.39 m		
(K)	0.60 m		
(L) with track pads 600 mm	2.99 m		
(L) with track pads 700 mm	3.09 m		
(L) with track pads 800 mm	3.19 m		
(M)	0.46 m		
(N)	1.40 m		



**Weight ( - A.92.A.40)**

CX225SR

**Weight of machine**

Configuration	Weight	Ground pressure
With track pads <b>600 mm</b> , monobloc boom <b>5.70 m</b> , dipper <b>2.40 m</b> , <b>760 kg</b> backhoe, driver and full fuel tank	<b>22 700 kg</b>	<b>0.47 bar</b>

**Weight of components**

Engine	<b>487 kg</b>
Hydraulic pump	<b>125 kg</b>
Attachment control valve	<b>187 kg</b>
Swing moto-reduction gear	<b>223 kg</b>
Travel moto-reduction gear	<b>250 kg</b>
Boom cylinder	<b>200 kg</b>
Dipper cylinder	<b>257 kg</b>
Bucket cylinder	<b>151 kg</b>
Counterweight	<b>5880 kg</b>
Cab	<b>kg</b>
Turntable	<b>244 kg</b>
Upperstructure with equipment (counterweight and turntable)	<b>11770 kg</b>
Hydraulic swivel	<b>27 kg</b>
Undercarriage with equipment	EUROPE <b>7020 kg</b> NA <b>7730 kg</b>
Machine without equipment	EUROPE <b>18840 kg</b> NA <b>19550 kg</b>
Attachment	<b>3870 kg</b>
Boom with equipment	<b>2200 kg</b>
Dipper with equipment <b>3.00 m</b>	<b>910 kg</b>
Dipper without equipment <b>3.00 m</b>	<b>599 kg</b>
Radiator and oil-cooler assembly	<b>55 kg</b>
Fuel tank	<b>160 kg</b>
Hydraulic reservoir	<b>145 kg</b>
Idler wheel	<b>82 kg</b>
Upper roller	<b>17 kg</b>
Lower roller	<b>35 kg</b>
Tension shock absorber	<b>142 kg</b>
Track <b>600 mm</b>	<b>1350 kg</b>
Track <b>700 mm</b>	<b>1570 kg</b>
Track <b>800 mm</b>	<b>1710 kg</b>

## Consumables ( - A.92.A.55)

CX225SR

### FLUIDS AND LUBRICANTS

Lubricants must have the correct properties for each application.

**ATTENTION:** You must respect the operating conditions for the different ingredients.

#### Hydraulic fluid

**CASE AKCELA** hydraulic fluid is specially designed for high pressure applications and for the CASE hydraulic system.

The type of fluid to be used depends on the ambient temperature.

- TEMPERATE COUNTRIES - **20 °C to + 40 °C**  
**CASE AKCELA HYDRAULIC EXCAVATOR FLUID**  
(MS 1230. ISO VG 46. DIN 51524 PART 2 HV)
- HOT COUNTRIES **0 °C to + 60 °C**  
**CASE AKCELA HYDRAULIC EXCAVATOR FLUID "HOT CLIMATE"**  
(MS 1230. ISO VG 100. DIN 51524 PART 2 HV)
- COLD COUNTRIES - **40 °C to + 20 °C**  
**CASE AKCELA HYDRAULIC EXCAVATOR FLUID "COLD CLIMATE"**  
(MS 1230. ISO VG 22. DIN 51524 PART 2 HV)
- BIODEGRADABLE FLUID - **30 - +40 °C**  
This yellow fluid can be mixed with standard fluid.  
If this liquid is used, it is advisable to completely drain the hydraulic circuit .  
**CASE AKCELA HYDRAULIC EXCAVATORS FLUID BIO**  
(MS 1230. ISO VG 46. DIN 51524 PART 2 HV)

#### Transmission component oil

Extreme pressure oil used in transmission components inside sealed housings.

**CASE AKCELA 135H EP GEAR LUBE SAE 80W-90**  
(SAE 80W-90. API GL 5. MIL-L-2105 D. MS 1316. ZF TE-ML 05A)

#### Grease

"Extreme Pressure" multi-purpose grease

- **CASE AKCELA MOLY GREASE 241H EP-M** (251H EP-M NLGI2)  
with lithium and molybdenum bisulphide soap.
- **CASE AKCELA 251H EP MULTI-PURPOSE GREASE** (251H EP. NLGI 2)  
with lithium and calcium soap.
- **CASE AKCELA PREMIUM GREASE EP-2** (NLGI 2)  
with lithium soap.

HYDRAULIC HAMMERS

Use only **CASE AKCELA PREMIUM GREASE EP-2** (NLGI 2) grease with lithium soap.

#### Engine oil

**CASE AKCELA NO. 1 ENGINE OIL** is recommended for the engine.

This oil provides correct lubrication for your engine in all working conditions.

If **CASE AKCELA NO. 1 ENGINE OIL** Multigrade cannot be obtained, use oil corresponding to one of the following categories: ACEA E5. MS 1121. API CH-4.

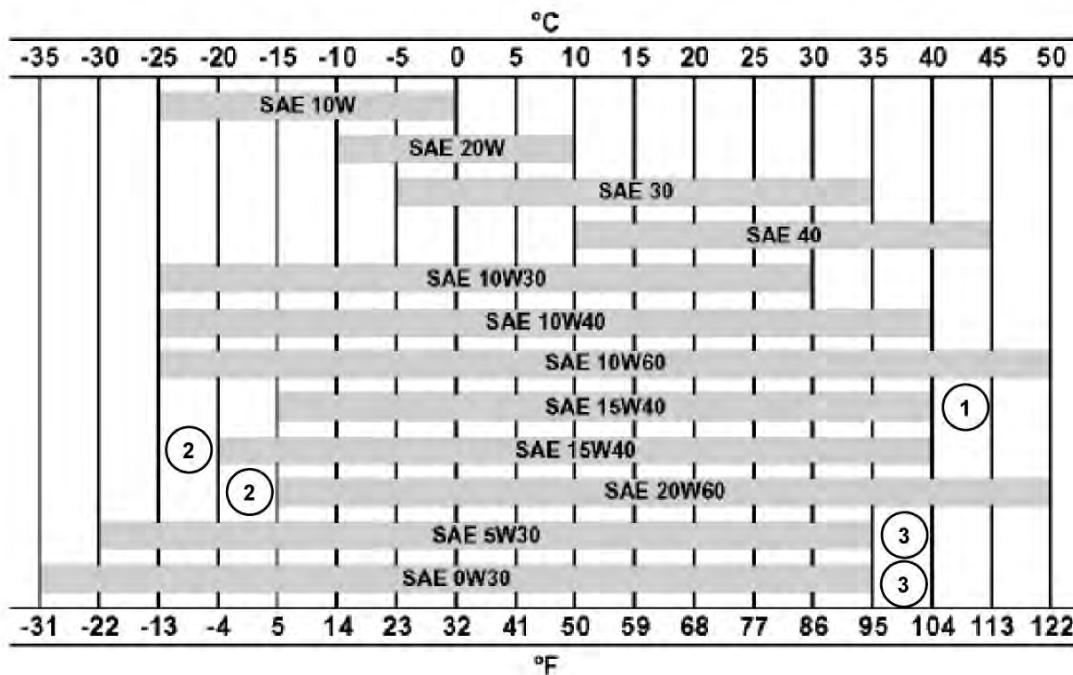

CRIL03H015F01

CRIL03H015F01 1

**OIL USE RANGE**

1. Mineral-based
2. Semi-synthetic based
3. Synthetic based

**Fuel**

Use fuel that is compliant with ASTM (American Society for Testing and Materials) standard D975.

- Use Grade No 2 fuel. The use of other types of fuel can result in a loss of power and may cause high fuel consumption.
- When the temperature is very cold, the use of a mixture of No 1 and No 2 fuel is permitted. See your fuel vendor for winter fuel requirements in your area.
- If the temperature falls below the fuel cloud point (point at which wax begins to form) the wax crystals will cause power loss or will prevent the engine from starting.

**IMPORTANT:** In cold weather, fill the fuel tank at the end of the day's work to prevent condensation from forming.

**FUEL STORAGE**

Long storage can lead to the accumulation of impurities and condensation in the fuel tank. Engine trouble can often be traced to the presence of water in the fuel.

The storage tank must be placed outside and the temperature of the fuel should be kept as low as possible. Drain off water and impurities regularly.

**Anti-freeze/Anti-corrosion**

Use anti-freeze in all seasons to protect the cooling system from corrosion and all risk of freezing.

**CASE AKCELA PREMIUM ANTI-FREEZE LRD -25°C**

For environments with temperatures falling to - 25 °C, do not mix with water.

**CASE AKCELA PREMIUM ANTI-FREEZE (MS 1710)**

For environments with temperatures falling to - 38 °C, use with water in a proportion of 50/50.

**IMPORTANT:** Do not mix products of a different origin or a different make. The system must be topped up with the same product.

## **Environment**

Before carrying out any servicing operation on this machine and before disposing of used fluids or lubricants, always think of the environment. Never throw fluid or oil on the ground and never keep them in leaking receptacles. Contact your local ecological recycling centre for information on appropriate ways to dispose of these substances.

## **Components made from plastic or resin**

When cleaning plastic parts, (the console, the instrument panel, the indicators etc...) avoid using petrol, paraffin, paint solvents etc.

Use only water, soap and a soft cloth. The use of petrol, paraffin, paint solvents, etc, will cause discoloration, cracking or deformation of these components.

---

## Hydraulic contamination ( - A.92.A.60)

CX225SR

### CLEANING THE HYDRAULIC SYSTEM

#### General

Contamination of the hydraulic system is a major cause of incorrect operation of hydraulic components. Contamination is indicated by the presence of foreign particles in the hydraulic fluid.

Contamination of the hydraulic system can occur in any of the following situations:

1. When draining the fluid or disconnecting a hydraulic line.
2. When disassembling a component.
3. Due to normal component wear.
4. Due to damaged or worn seals.
5. Due to a damaged component in the hydraulic system.

All hydraulic systems can function even if they are slightly contaminated. The components of the hydraulic system are designed to support slight contamination. Any increase in the degree of contamination can cause serious problems in the hydraulic system.

The following is an incomplete list of these problems:

1. The cylinder rod seals leak.
2. Control valve spools do not return to the neutral position.
3. Control valve spools do not move easily.
4. Hydraulic fluid is too hot.
5. Hydraulic components wear quickly.
6. Safety valves or check valves do not close due to contamination.
7. Repaired components break down soon.
8. Cycles are slow; the machine does not have enough power.

If any of the above situations occurs, it is an indication of excessive contamination of the hydraulic system. To eliminate contamination, effectively, refer to **PRIMARY HYDRAULIC POWER SYSTEM - Decontaminating (A.10.A - F.30.A.60)**.

#### Types of contamination

Contamination exists basically in two forms: microscopic or visible.

We speak of microscopic contamination when very small particles of foreign bodies are in suspension in the hydraulic fluid. These particles are too small to be seen or felt. Microscopic contamination can be detected by identifying the problems relating to microscopic contamination or by laboratory tests.

The following are a few examples of problems caused by microscopic contamination:

- The cylinder rod seals leak.
- Control valve spools do not return to the neutral position.
- The operating temperature of the hydraulic system is too high.
- Components wear quickly.

We speak of visible contamination when the presence of foreign bodies can be detected visually, by touch or by smell. Visible contamination can cause the sudden failure of a component.

The following are a few examples of problems caused by visible contamination:

- The fluid contains metal or other fragments.
- The fluid contains air. The fluid is dark and thick.
- There is a smell of burning in the fluid. The fluid contains water.